

# CELLULAR BEAMS DESIGN GUIDE



MARCH 2003

# Introduction

---

## **CELLULAR BEAMS**

Patented Cellular beams have proved to be one of the most significant developments in steel construction since their introduction in 1987. They have been used in over 3500 projects in over twenty countries.

The structural integrity and design criteria have been verified following full scale destructive testing at Bradford University in 1988, Leeds University in 1995 and the University of Manchester Institute of Science and Technology (U.M.I.S.T) in 2000, under the supervision of the Steel Construction Institute in the UK.

## **MACSTEEL TRADING**

Macsteel Trading, entered into an agreement with European cellular beam supplier, Westok Limited to manufacture and distribute cellular beams.

Macsteel Trading has an extensive branch network in Southern Africa. It provides economies of scale and exceptional service levels to the mild steel, special steels, pipes and fittings, fluid control, and value added markets .

Macsteel Africa supplies the full range of steel and value added steel products to Africa and the Indian Ocean islands

Macsteel Trading is committed to the highest quality of service and workmanship.

### **MACSTEEL TRADING (PTY) LTD**

#### **GERMISTON SOUTH**

Cnr. Simon Bekker and  
Crompton Roads, Germiston South  
P O Box 7729, Johannesburg 2000  
South Africa

Tel: (011) 871-4600

Fax: (011) 871-4667

Email: [design@mactrading.co.za](mailto:design@mactrading.co.za)

Web: [www.macsteel.co.za/cellbeam](http://www.macsteel.co.za/cellbeam)

# Contents

---

## Floors

- 4. Applications
- 5. Flexible Geometry and Properties
- 6-7. Clear Span or Short Span?
- 8. Service Integration
- 9. Dynamic Performance
- 10. Deflection / Cambers
- 10. Car Parks

## Roofs

- 11. Applications
- 12-14. Curved Beams
- 15. Tapered Beams & Cantilevers
- 15. Spine Beams

## Columns

- 16 Cellular Columns

## Design

- 17. Technical Support
- 17-18. How to Specify Cellular Beams
- 18-20. Avoiding Infills to Cells
- 20. Welding and Testing

CELLBEAM Program Design Guide  
And Section Property Tables

# FLOOR beams – Applications

The major use of cellular beams is as secondary floor beams to achieve one or both of the following:-

- LONG SPANS
- SERVICE INTEGRATION



Whether to use cellular floor beams is easily summarised:

	< 9m SPAN	< 12m SPAN	> 12m SPAN
<b>NO SERVICES</b>	X	✓	✓✓
<b>SINGLE SERVICE OPENING</b>	✓	✓✓	✓✓✓
<b>NORMAL/HEAVILY SERVICED</b>	✓✓	✓✓✓	✓✓✓

The optimum floor layout uses cellular floor beams as long-spanning secondaries. The primary member could be cellular or plain, dependent on whether services are required in both directions:-

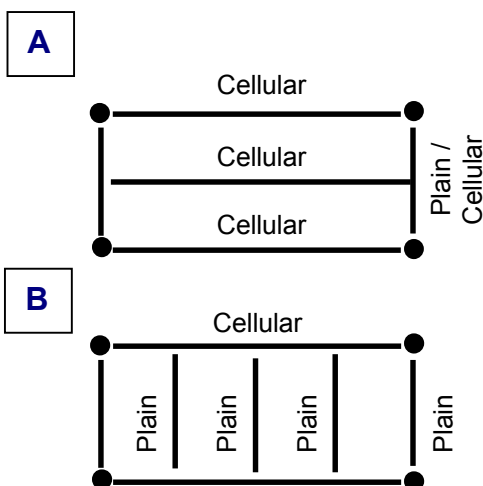

## ADVANTAGES OF LAYOUT A

- **Shallower construction**
- **Easier servicing**
- **Lower piece count/faster fabrication and erection**
- **Better dynamic performance**

# Flexible Geometry & Properties

The Geometry of cellular floor and roof beams are chosen to suit the requirements of each specific case.



Given the client's maximum depth and minimum service opening size the optimum cellular beam can be designed:-

## Example:

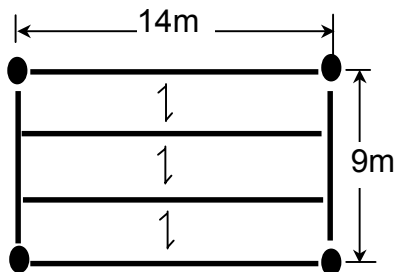

Live Load	4.0 kN/m <sup>2</sup>
Partitions	1.0 kN/m <sup>2</sup>
Services, Ceilings & Finishes	0.5 kN/m <sup>2</sup>
	Slab 130 mm

### Client Brief 1

### Optimum solution to brief 1

Depth Limit **650 mm maximum**

 UB 406x178x54

**68 kg/m**

Service Openings **400 mm minimum**

 UB 533x210x82

**24kg/m<sup>2</sup>**  
**Floor Weight**  
(excl columns)

### Client Brief 2

### Optimum solution to brief 2

Depth Limit **400 mm maximum**

 UB 254x254x89

**113 kg/m**

Service Openings **250 mm minimum**

 UB 305x305x137

**42kg/m<sup>2</sup>**  
**Floor Weight**  
(excl columns)



# Clear Span or Short Span ?

## BUILDING HEIGHT / CLADDING

## CLEAR SPAN BENEFICIAL

The passage of ducts within the cellular beam produces shallower overall depths than short –span layouts with underslung services.

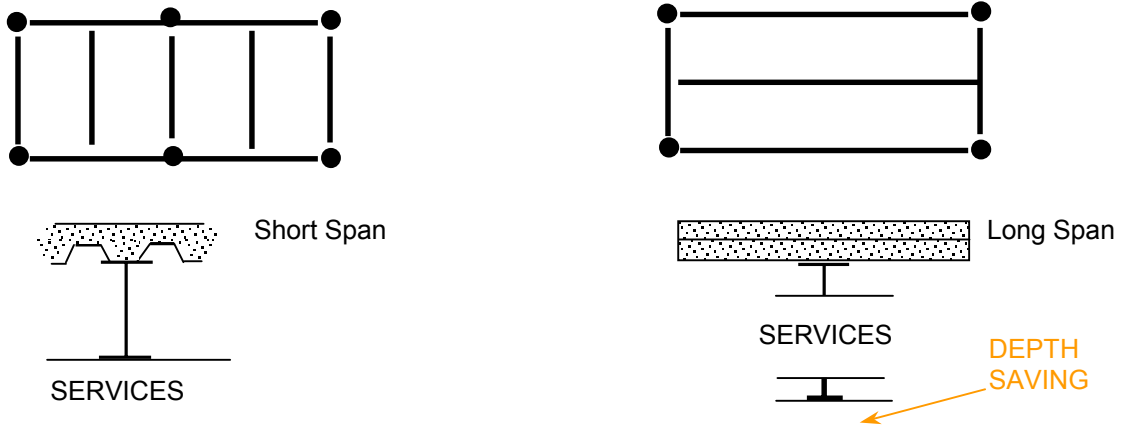

SERVICES (see pages 8)

## CLEAR SPAN BENEFICIAL

## TRADITIONAL FIRE PROTECTION

## CLEAR SPAN BENEFICIAL

Overall surface areas are reduced or similar due to smaller piece-count with the clear span approach. A clear–span layout also has fewer columns to fire protect.

## INTUMESCENT FIRE PROTECTION

## CLEAR SPAN BENEFICIAL

The higher HP/A values and lower piece count of the clear-span approach give enormous benefits when the steel is intumescently coated. Long-span beams have lower load ratios, allowing thinner and fewer coats, saving materials and application costs. Thinner coats dry quicker and incur less damage during transportation and erection.

## FOUNDATIONS

## CLEAR SPAN BENEFICIAL

The reduced number of foundations gets the contractor “out of the ground” much earlier. Reducing the number of foundations significantly reduces the risk on contaminated sites, and massively reduces the cost of piled sites.



# Clear Span or Short Span ?

## ENVIRONMENTAL

## CLEAR SPAN BENEFICIAL

The most common reason for commercial office buildings becoming redundant is dissatisfaction with layout.

**A layout free of internal columns provides total flexibility from day one and throughout the lifetime of the building.**

## FABRICATION

## CLEAR SPAN BENEFICIAL

The much smaller piece count reduces the number of end connections. Material handling is significantly reduced at every stage of fabrication.

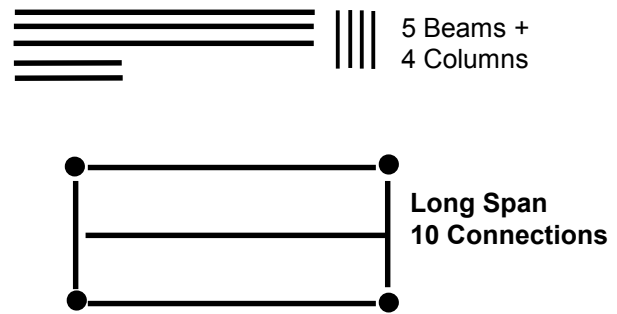
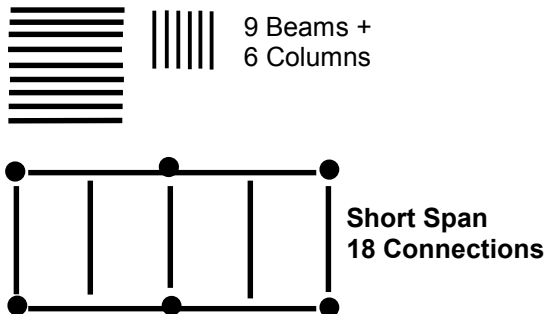

## ERECTION

## CLEAR SPAN BENEFICIAL

On site the number of picks and fixings are dramatically reduced. A clear-span structure is significantly faster to erect.

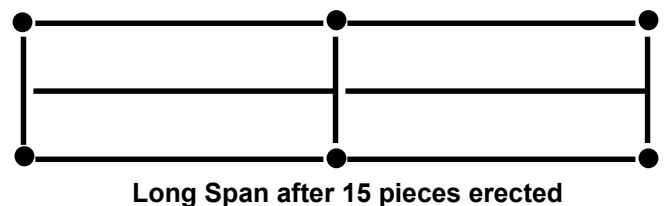
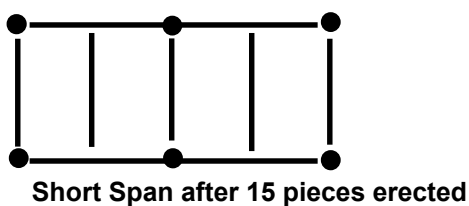

## WEIGHT

## CLEAR SPAN PENALTY

The **only** penalty with the clear-span approach is the slight increase in weight of the structure. Including the area common to both approaches, eg. roof, cores, staircases etc. the weight difference is no more than 20%. This represents only 1% of total building costs.

**THE SLIGHTLY HIGHER WEIGHT IS MORE THAN OFFSET BY COMBINED COST BENEFITS FROM OTHER BUILDING ELEMENTS.**

# Service Integration

One of the major benefits of cellular beams is the ability to use circular ducts. This is the least expensive and most efficient way of servicing a building.

## MINIMUM CONSTRUCTION COSTS

- **Upto 3 circular ducts can be supplied and fitted for the cost of one rectangular duct.**
- **Circular ducts require fewer or no supports**
- **Circular ducts are available from stock in standard sizes.**



## MAXIMUM FLEXIBILITY

- **Flexibility for changes to services throughout the design and site programme.**
- **Flexibility for the client to add/change service requirements throughout the lifetime of the building.**

## MINIMUM LIFETIME RUNNING COSTS

- **Circular ducting significantly reduces energy consumption compared to rectangular ducting.**

## ELONGATED OPENINGS

### Design

Elongated openings for rectangular ducts can be designed using the CELLBEAM software. Macsteel Advisory Engineers will assist in their design, including advice on the need for and or most economical details of any stiffening.



### Benefit?

The benefit of elongated openings is questionable. Circular ducting is cheaper and more efficient than rectangular, and fabricating elongated opening in any type of steel beam carries a significant cost. It is common consensus that ducting will continue to decrease in size. The huge number of circular openings in a cellular floor beam are more than sufficient to “Future Proof” the building for the changing needs of the client. **The lowest cost building will have circular ducts and cellular beams without elongated cells.**

# Dynamic Performance

## WHY CELLULAR BEAMS?

- Cellular beams provide a higher “quality” of floor compared to shallow beams with squashed-up services, by using the full ceiling void which maximizes inertia and stiffness.



## WHY CLEAR SPAN?

- Research and testing has confirmed that clear-span floors can be of higher quality than short-spans.

SCI, UK Design Guide P.76 concludes that natural frequency is not the most reliable predictor of floor quality. Frequency i.e. the number of times the beam oscillates per second, is imperceptible by humans. It is the amplitude that is actually felt in the form of acceleration. **(The reference can be found in the SAISC Library)**

It is possible for a floor with an “acceptable” frequency well above 4 Hz to produce an unsatisfactory “feel”, whilst a floor designed below 4 Hz can produce an exceptionally high quality floor. SCI’s published method (Design Guide P.76) of designing floor quality is to calculate the response factor, R, which is indirectly proportional to the quality of floor:-

R	≤ 12	Suitable for busy office floor
R	≤ 8	Suitable for a general office floor
R	≤ 4	Highest quality office floor

Westok (Ltd) has collaborated with the SCI, UK, CTICM, Oxford University and City University in research into floor vibration, including in-situ physical tests on several floors in the UK and France. The testing has conclusively proved that increasing the span does not result in a lower quality of floor.

Below is a comparison of two of the tested structures:-

### Frame A

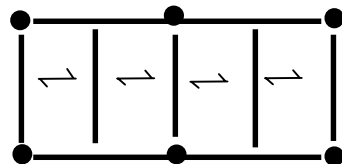

- Span 9m
- Structure & Services 740 mm
- Tested Frequency 6 Hz
- R value 8
- “Suitable for general office”

### Frame B

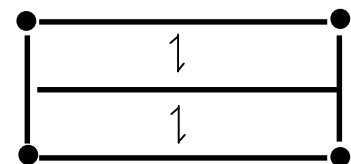

- Span 16.9m
- Structure & Services 580 mm
- Tested Frequency 4.5 Hz
- R value 4
- “Highest quality office floor”

**CLEAR-SPAN FLOORS HAVE GREATER MASS, RESULTING IN LOWER ACCELERATIONS.**

# Deflections / Cambers

## DEFLECTION

Deflections on long span beams can require the specification of costly pre-cambers. Cellular beams are easily pre-cambered as part of the manufacturing process **without additional cost.**

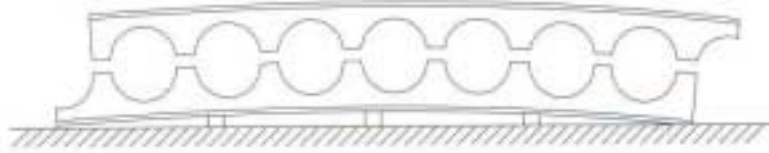

Pre-cambering upto 100mm free of charge.

## PRACTICAL CONSIDERATIONS

Pre-cambers should be sufficiently pronounced so that they can easily be identified in the fabricator's workshop and on site. As a guide the following rules should be applied:-

- No cambers < 10 mm
- No cambers < span/1000

# Car Parks

At nominally 16 meter spans under car park loadings a cellular beam is an extremely efficient structural member. In addition to its light weight, a cellular beam provides three significant benefits in car park construction:

## Pre-Cambers

Cellular beams can be pre-cambered at no cost during production to offset a proportion of the dead-load deflection. Large cambers allow the natural drainage of surface water.

## Appearance & Personal Security

The large web openings provide a light and airy interior to improve personal security, increasingly demanded by clients for modern parking areas.

## Smoke Ventilation

Stricter health & safety regulation dictates the need to consider the problems of smoke ventilation. The regular web openings accelerate smoke dispersion compared to solid web beams.



# Roof Beams - Applications

The economic span range depends on the loading and frame centers, but may be generalized as below:

	≤ 20m SPAN	20 - 40 m SPAN	> 40m SPAN
PITCHED PORTAL	X	✓	✓✓
CURVED PORTAL	✓	✓✓	✓✓✓
STRAIGHT SIMPLY-SUPPORTED	✓✓	✓✓✓	✓✓✓
CURVED SIMPLY-SUPPORTED	✓✓✓	✓✓✓	✓✓✓

The production process considerably improves the section properties of the parent beam used. **The cellular beam is up to 1.6 times deeper than its parent universal beam, and more importantly up to 7 times stronger.**

## COMPARISON V TRUSSES

Beyond the range of portal-frame construction cellular beams are the ideal solution.

A cost comparison between cellular beams and trusses invariably favours cellular beams. Built-up truss fabrication is more labour intensive and painting costs are considerably higher.



# Curves

Cellular beams are the perfect solution for curved roof applications, combining a considerable weight saving compared with plain sections and a low-cost manufacturing process.



## Step 1

Two beams are split, the first using A special top tee (Orange) and the second using a special bottom tee Cut (blue).

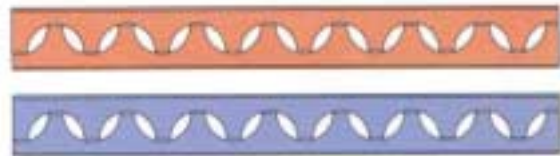

## Step 2

A bottom tee is bent to the Required radius.

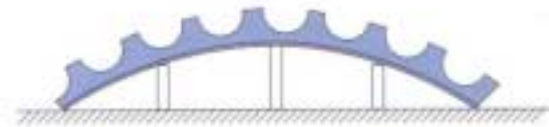

## Step 3

A top tee is curved and welded to The bottom tee.  
The process is repeated using the so far unused tees to create a pair of curves.

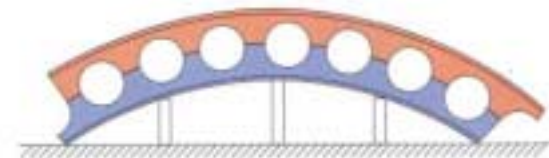

# Curves - Economics

## Pitched Roof or Curved Roof?

The cost difference between pitched and curved roof construction has never been as low as it is today. The minimum cost difference is likely to be achieved at a radius of around 150m. This minimizes the number of splices required and allows the use of standard roof cladding products.

## Braced Frame or Curved Portal Frame?

A portal solution provides a cost-effective frame but with the penalty of large stanchions. In many applications this is undesirable. A braced frame solution using simply supported curved cellular beams allows slender columns, often containable within the wall construction.

## Plain Beams or Cellular Beams?

Cellular beams offer economies compared to plain universal beams due to weight savings of up to 40% and the ease of curving.

The relative cost of plain and cellular beams depends on many factors, but may be generalized below.

	<b>Tight Radius</b>	<b>Medium Radius</b>	<b>Large Radius</b>
<b>Up to 16m Span</b>	<b>Plain</b>	<b>Plain/Cellular</b>	<b>Cellular</b>
<b>&gt; 16m Span</b>	<b>Plain/Cellular</b>	<b>Cellular</b>	<b>Cellular</b>



# Achievable Radii

Curved cellular beams fall into two categories:

- A) Curved in-house, therefore minimum cost
- B) Curved in collaboration with a section-bending company

The table below indicates the approximate limits of the respective methods.

ORIGINAL SECTION SIZE	TYPICAL BEAM DEPTH	LENGTH OF BEAM	MINIMUM RADIUS	
			A	B
Up to 305X165	450	10m	20m	15m
		12m	30m	
		14m	40m	
		16m	50m	
		Up to 457x191	650	
16m	60m			
18m	80m			
20m	95m			

The achievable radius of a beam is not subject to overall span, but to the length of the pieces.

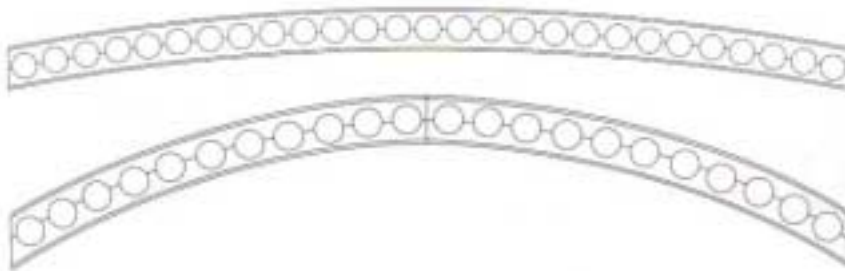

A tighter radius can be achieved by introducing a splice. Splices at 1/3 points allow a further reduction in radius.

# Tapered Beams & Cantilevers

Cellular beams provide a very economical method of producing tapered members.

Step 1: Profile at angle of required taper



Step 2 : Spin one tee 180°, and re-weld

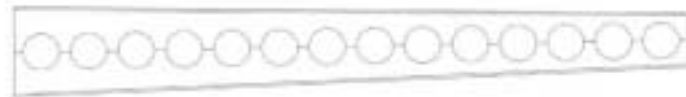

Long cantilevers can be made by splicing multiple sections.



Simply supported tapered beams in a pitched roof minimize building height.

## Spine Beams

Hit and miss spine beams are a common method of increasing usable floor space in a single storey building. Cellular beams efficiently span 3, 4 or even 5 bays between columns, creating vast open floor areas at minimum cost. Cellular spine beams also eliminate expensive rafter/spine dropped haunch arrangements.

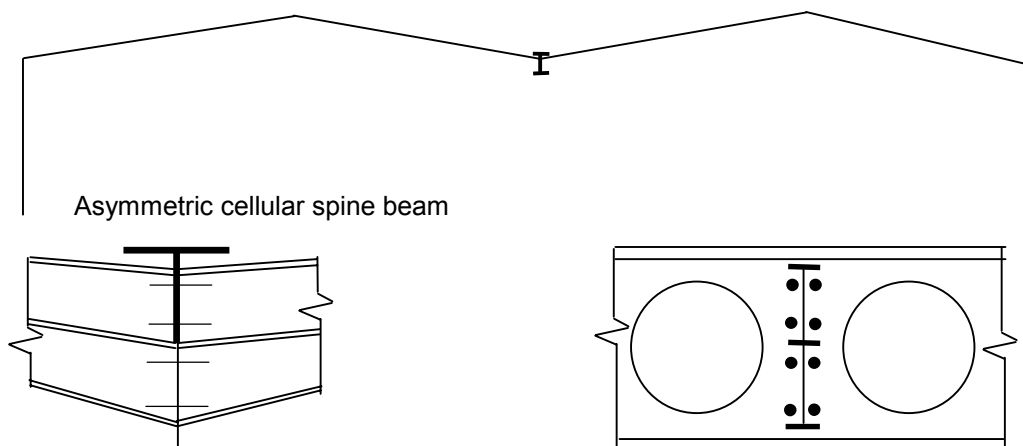

Cellular spine beams can be cambered free of charge for drainage. Asymmetric sections maximize efficiency where subjected to lateral torsional buckling.

# Columns

Cellular columns are most efficient in cases where axial loads are small, such as gable columns and wind-posts.

High-bay columns are a particularly suitable application, where the increased inertia of a cellular beam is required for the large deflections in the tall columns.

In conditions where wind-reversal is the dominant criterion, asymmetric cellular beams can be adopted, using the wider tee as the unrestrained flange.

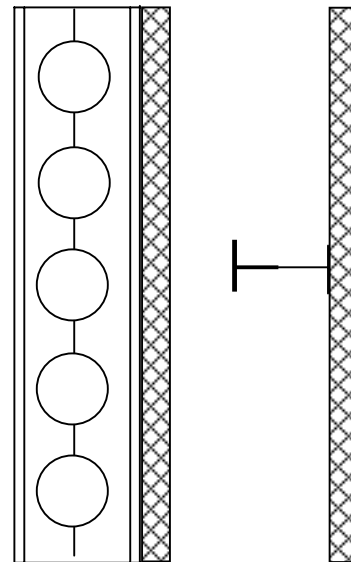

Asymmetric Columns for wind reversal



# Design, Technical Support

## OFFICE BASED DESIGN SERVICE

Macsteel Trading have an office based design service to provide advice and full designs. To help optimize the design of a specific project and assist engineers to gain familiarity and expertise in cellular beam design, Macsteel Trading staff will attend project design meetings.

## TECHNICAL SEMINARS

In house technical seminars can be arranged to promote the efficient design of cellular beams, and proficiency with the associated software, CELLBEAM.

## CELLBEAM SOFTWARE

All cellular beam designs are carried out using the analysis program, CELLBEAM, written by the Steel Construction Institute UK. The results are based on full scale testing:

- Bradford University 1988
- Leeds University 1995
- U.M.I.S.T 2000

The program is available free of charge and is enhanced on a regular basis.

**Technical support will be offered without charge or obligation. Please do not hesitate to use it.**

## How to specify Cellular Beams

Given the flexibility of cellular beam geometry, a tabulated specification on drawings is the best way of conveying information to all interested parties.

The table shown below is not the only solution, but is one of the most commonly used approaches:

Beam Mark	Depth mm	Mass Kg/m	Material	Ribbon Cut	Grade	Cell Data			Camber	Notes	Studs 19mm
						Dia	pitch	infills			
CB1	466	82	top 356x171 I-section 67kg/m	None	300W	300	450	See dwgs	30mm	CL cell 300mm from top flange	2 per trough
			btm 305 x 305 H-section 97kg/m	None	300W						

# How to specify Cellular Beams

## NOTATION

The standard notation of an asymmetric cellular beam (A.C.B.) using the above example is as follows:

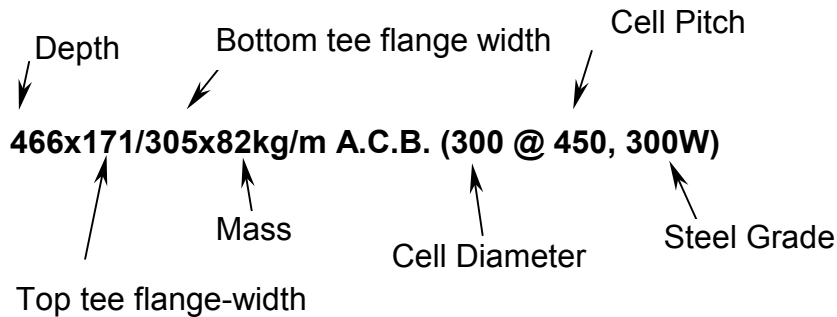

The standard notation of a symmetrical cellular beam (C.U.B), is as follows:

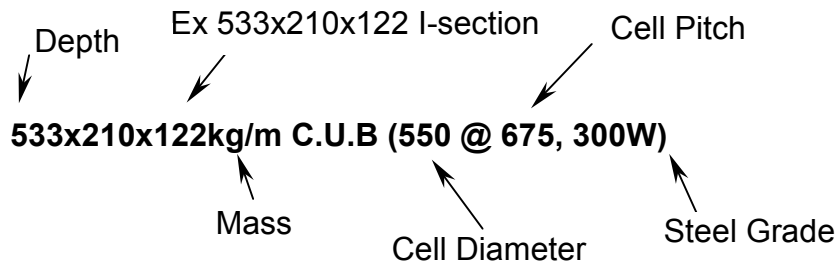

## Avoiding Infill to Cells

### Eliminating Infills

To avoid the unnecessary infilling of cells, care should be exercised in specifying the distance to the first cell.

- **Step 1** – Design the optimum members for structural efficiency.
- **Step 2** – Make slight adjustments to cell-pitch so that there is a full web-post at each end of the beam using the equation below, where n is the number of cells:-

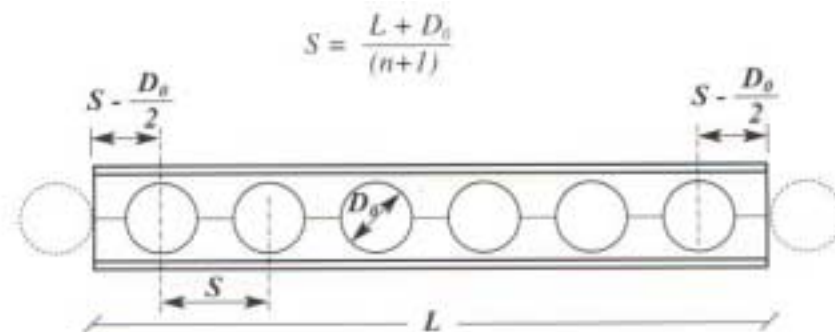

- **Step 3** – Re-check design using the new cell-data.

# Avoiding Infill to Cells

**CHANGING THE CELL PITCH BY ONLY A FEW MILLIMETERS CAN OFTEN COMPLETELY ELIMINATE INFILLS.**

## Roof Beams

In simply supported designs, infills should not be required. Irrespective of whether straight or curved, it should be possible to leave a full web-post at the beam ends.

In fixed-end or portal conditions consult Macsteel Trading.

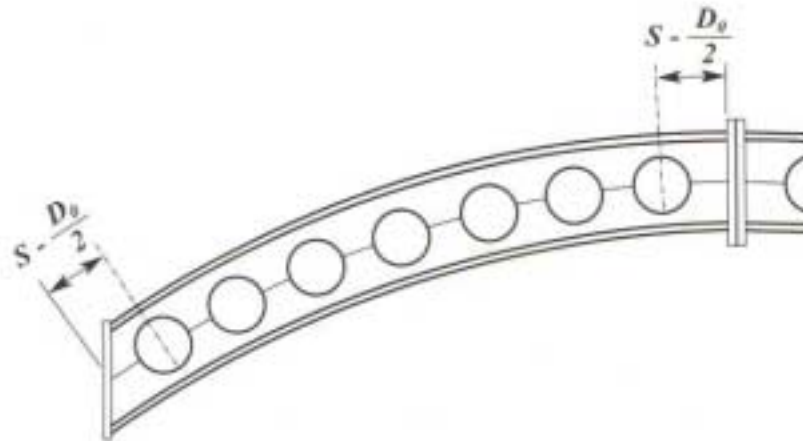

## Floor Beams

In a serviced floor the best approach is to optimize the cell pitch so that no infills are required for the beams on the grid. This fixes the cell layout for the intermediate beams.

The example shown below is typical, limiting the infills to only two half cells in every other beam:-

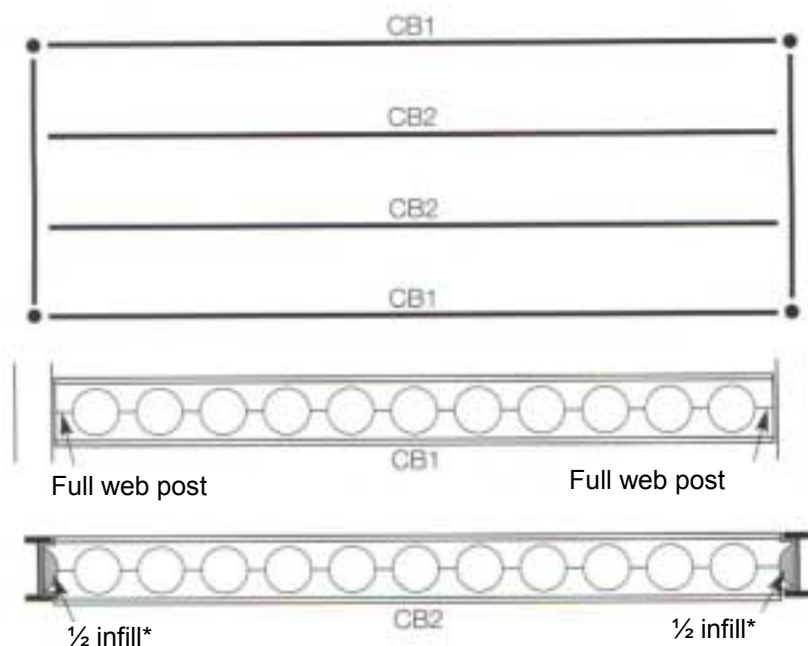

# Avoiding Infill to Cells

\* Steelwork contractors are increasingly choosing a fin-plate connection, which completely avoids notching and half infills.

Even in irregular buildings, infills can normally be limited to no more than an average of one per beam.

If your design requires more infilling than suggested above please consult Macsteel Trading. Our Advisory Engineers will help you minimize / eliminate infilling.

## Welding and Testing

### IN HOUSE TESTING – Non Project Specific

Macsteel Trading cellular beams only produce castellated and cellular beams. As a result Macsteel Trading is highly skilled in this welding technique.

A percentage of output is tested and verified by an independent testing company. Inspections are completely random, using Ultrasonic and Magnetic Particle Inspection methods. Whilst this does not guarantee the testing of a given beam or project, it ensures total confidence in weld quality at all times. The records of these random tests are available for inspection by any party at any time.

### DIFFERENT TESTING REQUIREMENTS

Macsteel Trading will test the welds of a project to any specific requirements.

It is important to make testing requirements clear in the projects specification.

Any testing must be carried out at Macsteel Trading.

